

Rockwell service bulletin

International

No. SB-AG-9

P.O. BOX 3090 ALBANY, GEORGIA 31706-3090 PHONE 229/883-1440 FAX 229/439-9790

Service Bulletin No. SB-AG-9
12 January 1977

RUDDER HINGE INSPECTION

MODELS AFFECTED: MODEL S-2R, SERIAL NO'S 5000 THRU 5082

REASON FOR PUBLICATION: POSSIBLE CRACKS IN RUDDER HINGE BUSHINGS.

COMPLIANCE: UPON RECEIPT OF THIS SERVICE BULLETIN AND ANNUALLY THEREAFTER.

NOTE

IF ANY PROBLEMS ARE ENCOUNTERED WHILE COMPLYING WITH THIS SERVICE BULLETIN, CONTACT YOUR NEAREST THRUSH COMMANDER DEALER OR YOUR THRUSH COMMANDER REGIONAL SERVICE MANAGER (REFERENCE SERVICE INFORMATION NO. SI-123).

BY WHOM WORK WILL BE ACCOMPLISHED: A & P MECHANIC OR EQUIVALENT AND CERTIFIED WELDER.

APPROVAL: FAA DER Approved.

ESTIMATED MAN HOURS: INSPECT HINGE BUSHING ONLY – THREE (3) HOURS
INSPECT & REPLACE HINGE BUSHINGS – FIVE (5) HOURS.

PARTS DATA: 1 ea. Compliance Card

NOTE

If replacement parts are required, they may be ordered, by following standard procedures, through your nearest Thrush Commander Dealer.

SPECIAL TOOLS: NONE

ACCOMPLISHMENT INSTRUCTIONS:

1. Remove rudder assembly from airplane.
2. Strip fabric from area around rudder hinges to facilitate inspection.

3. Inspect in and around weld bead on rudder hinge bushing for cracks (see Figure 1.).
4. If no cracks are found, proceed to step 6.
5. If cracks are found, proceed as follows:
 - a. Remove hinge bushing and check hinge doubler for cracks.
 - b. If no cracks are found in hinge doubler, proceed to step 5.d.
 - c. If cracks are found in hinge doubler, grind cracked area clean and weld in accordance with FAA Advisory Circular AC 43.13-1, Chapter 2 and grind weld smooth.

NOTE

If unable to grind out and clean up cracked area, it will be necessary to replace rudder assembly.

- d. Locate and tack weld new 9038-024 bushing and 90044-19 plate (2 lower hinges) or 5-4030-80 plate (upper hinge only) on existing hinge doubler in accordance with FAA Advisory Circular AC 43.13-1 Chapter 2 (see Figure 1.).
- e. Temporarily install rudder assembly on vertical stabilizer to assure no preload on hinges prior to final welding of hinge bushings.
- f. Remove rudder assembly and weld hinge bushings on rudder in accordance with FAA Advisory Circular AC 43.13-1, Chapter 2.

NOTE

Add a weld bead on top and bottom of rudder hinge bushing plate and grind smooth. Assure that fabric is protected from heat during welding.

- g. Check rudder hinges with straight edge or a string to assure proper alignment of hinge bushings (see Figure 2.).
 - h. Press fit P26-6 bushing in new bushing(s) (see Figure 1.).
6. Check for left and right alignment of rudder assembly to vertical stabilizer by installing rudder assembly on airplane and installing center and lower hinge pins only. If out of alignment, straighten or replace rudder assembly as necessary.
 7. Repaint and recover rudder assembly in area around rudder hinges with new fabric in accordance with FAA Advisory Circular AC 43.13-1, Chapter 3.
 8. Install rudder assembly on airplane by aligning and installing upper and lower hinge pins first.

Service Bulletin No. SB-AG-9
12 January 1977

9. If center hinge point does not align with vertical stabilizer hinge (forward and aft alignment), add shim(s), as necessary, to vertical stabilizer upper and lower attach point for proper alignment of hinges (see Figures 2.).

NOTE

Fabricate shims 3.00" x 3.75" (upper shim). 2.25" x 3.75"
(lower shim) from 2024T3 aluminum (thickness as
required) (see Figure 2.).

10. Fill out and mail Compliance Card.

ELECTRICAL LOAD: NO CHANGE

WEIGHT AND BALANCE: NO CHANGE

PUBLICATIONS AFFECTED: NONE

RECORD COMPLIANCE: Make appropriate entry in airplane maintenance records as follows: Service Bulletin No. SB-AG-9, dated 12 January 1977, entitled "Rudder Hinge Inspection", accomplished _____(dated)_____.

SERVICE BULLETIN NO. SB-AG-9

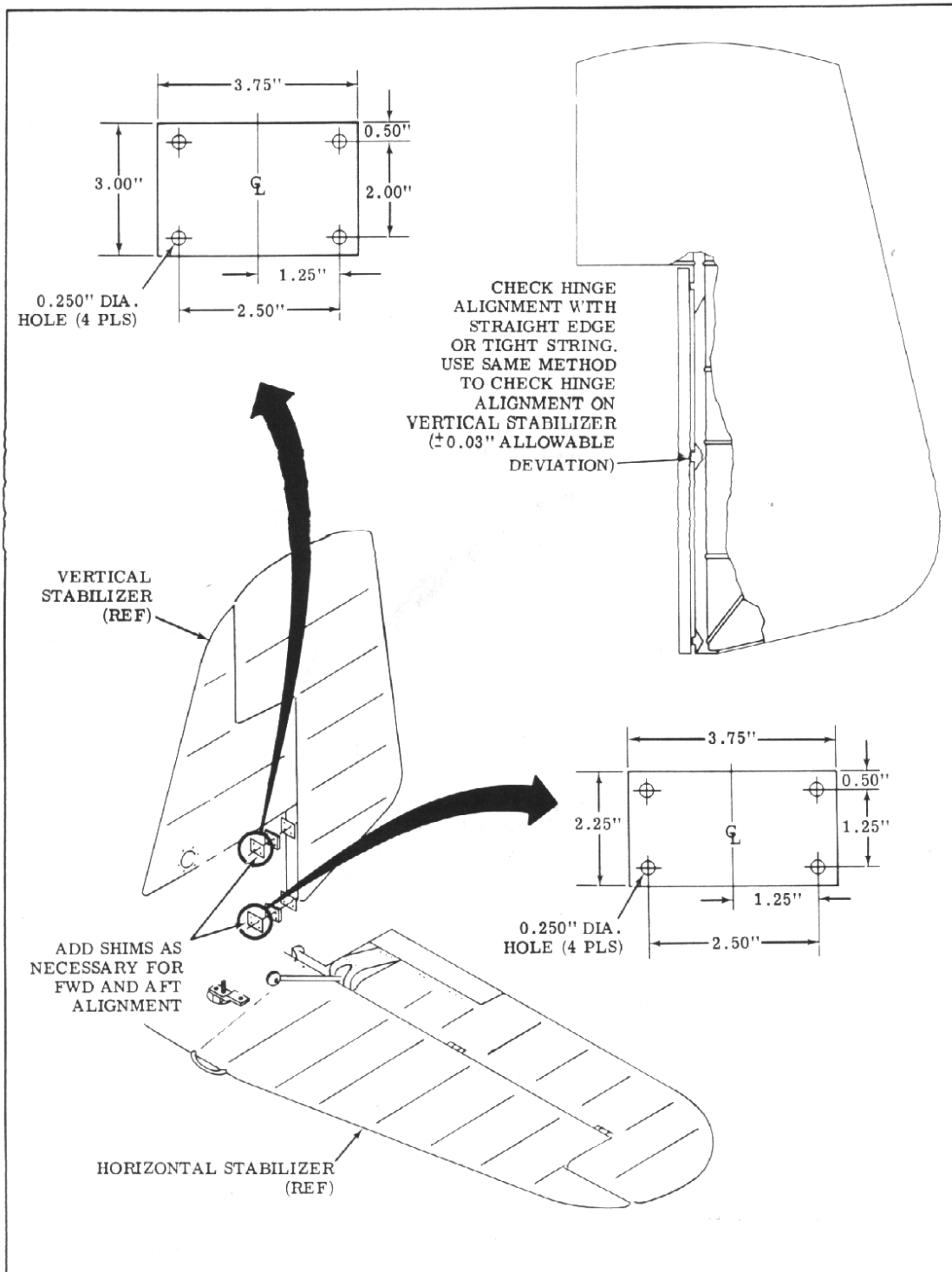

Figure 2.

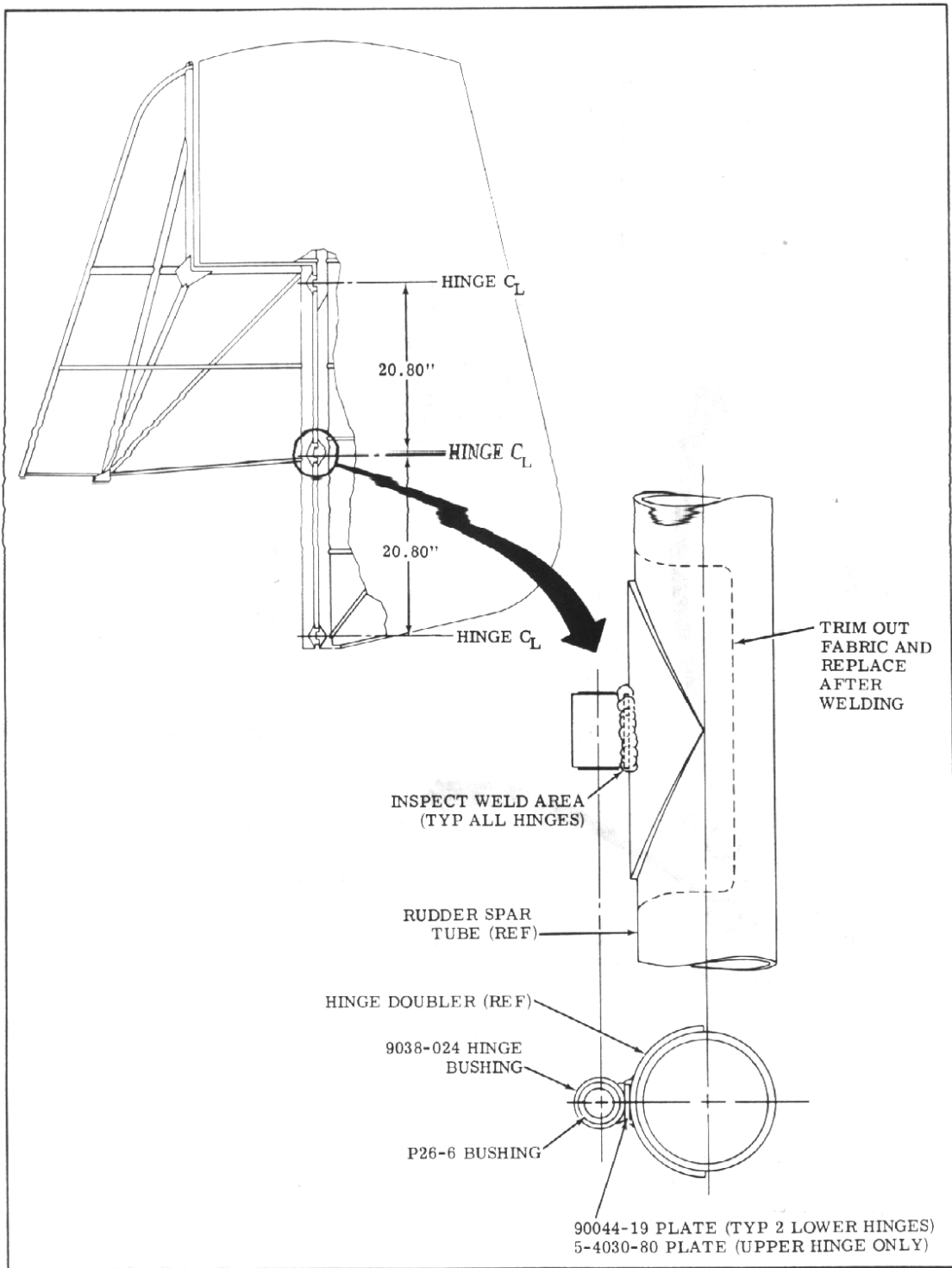

Figure 1.