



300 Old Pretoria Road Albany, Ga 31721
Phone: 229.883.1440 Fax: 229.439.9790
www.thrushaircraft.com

SERVICE BULLETIN

NO. SB-AG-68

Initial Release: 05/18/2018

FWD FIREWALL MODIFICATION

AIRPLANES AFFECTED:

MODEL
S2R-H80

SERIAL NUMBERS
H80-101 thru H80-122 SC or DC

A handwritten signature in blue ink, appearing to read "James Alman", written over a horizontal line.

James Alman

Vice President of Engineering

LOG OF REVISIONS

NOTE: Reformatting and correction of typographical errors is not considered revision. True revisions are indicated by a dark vertical line at the right margin of the lines revised.

Rev.	Page	Description of Revision	By:
IR	All	New Document Initial Release.	K. Sheppard 05/18/2018

1. Contents

LOG OF REVISIONS.....	i
1. PURPOSE/ REASON FOR PUBLICATION:	4
2. SCOPE/COMPLIANCE:.....	4
3. BY WHOM WORK WILL BE ACCOMPLISHED:	4
4. APPROVAL:	4
5. MAN HOURS:	4
6. SPECIAL TOOLS:	4
7. PARTS LIST	4
8. REPAIR/ MODIFICATION:	5
9. RECORD OF COMPLIANCE:.....	9
10. RESPONSE CARD	9

2. PURPOSE/ REASON FOR PUBLICATION:

Thrush Aircraft, Inc. has implemented a stiffener to the FWD firewall to improve the structural stability.

3. SCOPE/COMPLIANCE:

This service bulletin is for affected SR2-H80 airplanes.

4. BY WHOM WORK WILL BE ACCOMPLISHED:

The work is to be accomplished by an FAA licensed A&P mechanic, or foreign equivalent. The work must be recorded in the airplane log book and signed off by the A&P mechanic.

5. APPROVAL:

This service bulletin is approved by Thrush Aircraft, Inc.

6. MAN HOURS:

2 Hours will be required for modification/repair.

7. SPECIAL TOOLS:

No special tools required.

8. PARTS LIST

Parts are available through your local Approved Thrush Repair Center.

QUANTITY	P/N	DESCRIPTION
1	713020063	Stiffener
6	MS20615-4MX	Rivet
5	NASM27039C0810	Screw
10	AN960C8	Washer
5	MS21045C08	Nut

9. REPAIR/ MODIFICATION:

- Remove cowlings shown in Figure 68-1.

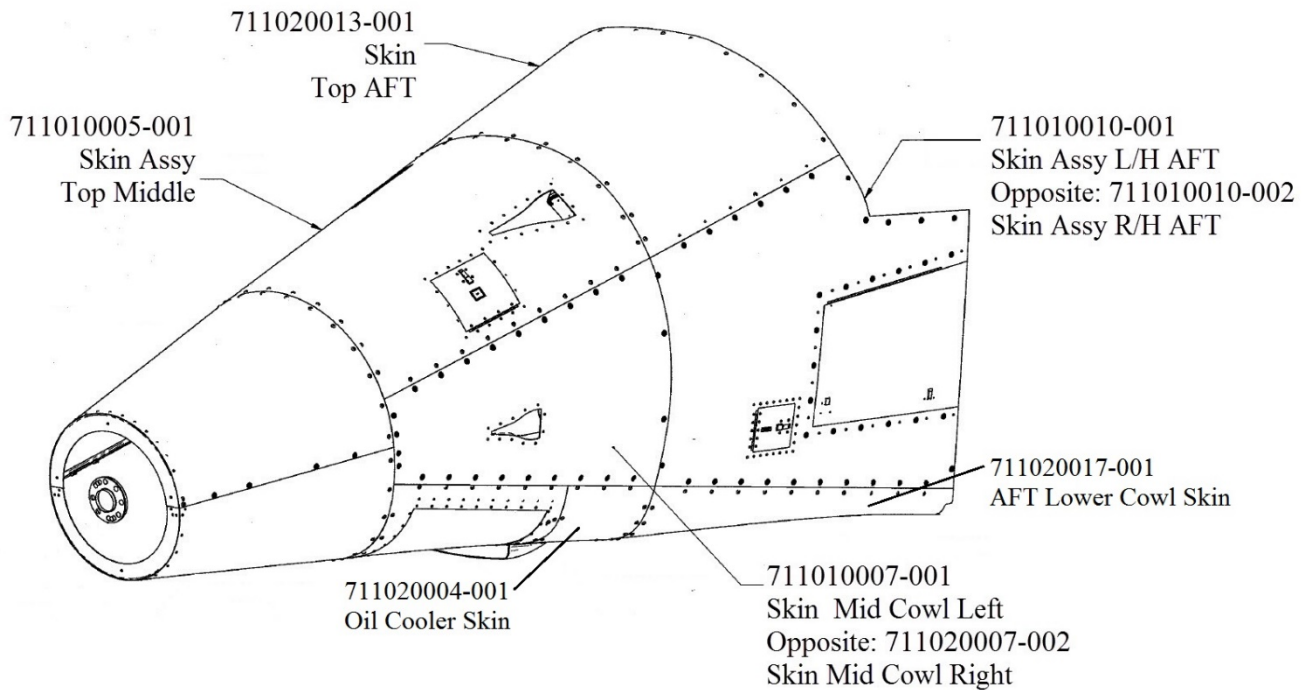

Figure 68-1

- Align Stiffener 713020063 to AFT firewall surface .34 inches below the 4th bolt from the bottom in the joggle. Ensure stiffener is parallel to the edge of the bottom FWD firewall panel 713020007. Stiffener should be equal distance between the left firewall panel 713020004 and right firewall panel 713020003. Shown in Figure 68-2.

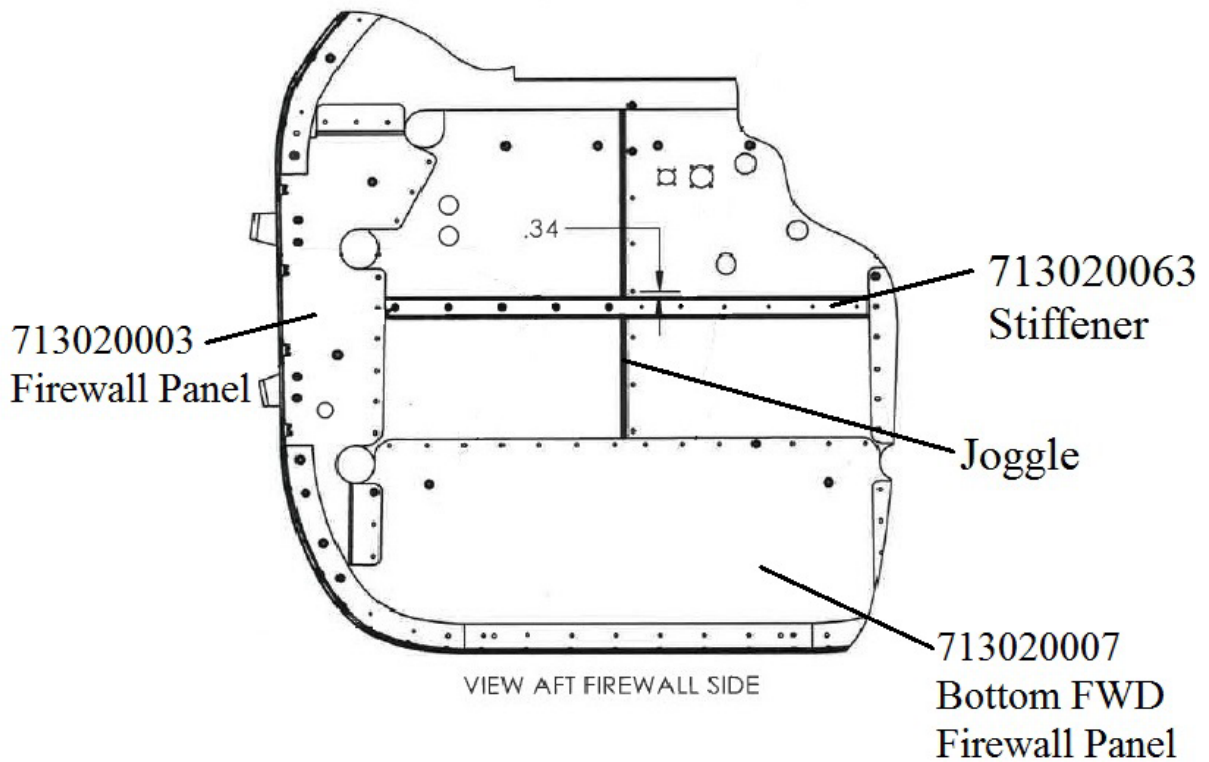
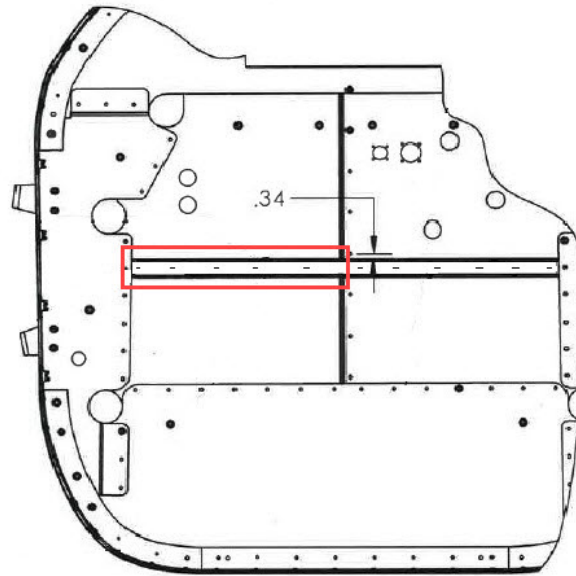

Figure 68-2

- Match drill (5) #19 holes through Left Middle FWD Firewall Panel 71302006 and Stiffener 713020063. See Figure 68-3.



VIEW AFT FIREWALL SIDE

Figure 68-3

- Match drill (6) #30 holes through Right Inboard Firewall Panel 713020005 and Stiffener 713020063. See Figure 68-4.

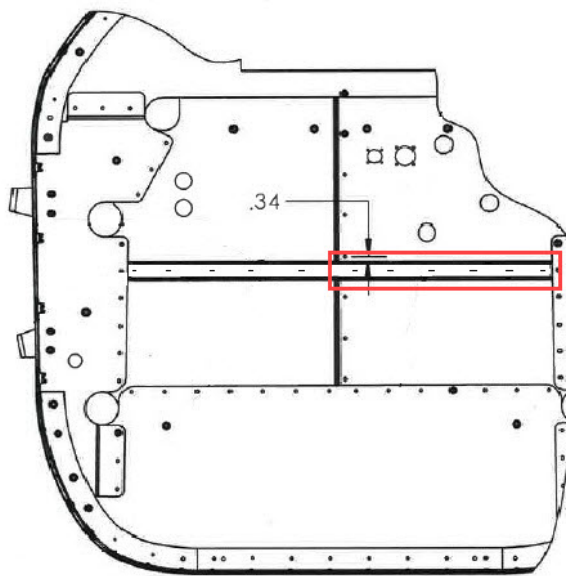

VIEW AFT FIREWALL SIDE

Figure 68-4

- Install stiffener on AFT surface of firewall panel using hardware shown in Figure 68-5.

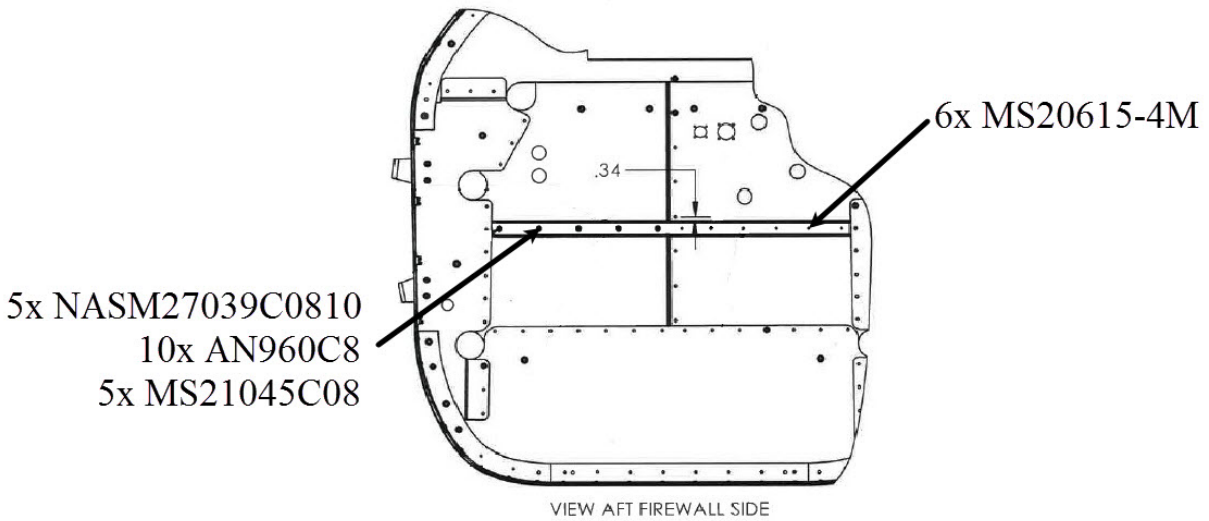

Figure 68-5

- Reinstall cowlings as shown Figure 68-1.

10.RECORD OF COMPLIANCE:

Make Appropriate entry in aircraft maintenance records as follows:

“Thrush Service Bulletin SB-AG-68 Rev. IR complied with at ____ total hours on aircraft. Modification accomplished by: _____

Name & Certificate #

Date:

11. RESPONSE CARD

The final step in compliance with this Service Bulletin is to complete and return the compliance card on the next page. It may be mailed, faxed, or scanned and e-mailed.

Fax to: Ed Rusk 229-439-9790

E-mail to: Ed Rusk erusk@thrushaircraft.com

Service Bulletin SB-AG-68

Aircraft S/N:	Aircraft Owner:
Aircraft Registration:	Address of Owner:
Airframe Total Time:	City & State:
Engine Total Time:	Physical Location:
Complied with By:	Certificate #:
Signature:	Date of Compliance:

PLEASE RETURN THIS REPORT ONLY AFTER REPAIR IS COMPLETED

This response card may be mailed, faxed to (229) 439-9790, or e-mailed to erusk@thrushaircraft.com.

Fold, Tape & Mail (Do Not Staple)

Return Address

Thrush Aircraft Inc.
 Attn: Ed Rusk
 300 Old Pretoria Road
 Albany, Ga 31721